

# *Transport and Climate Change*

*Research on the Reduction of Emission of  
Greenhouse Gases from the Icelandic Fishing  
Fleet and Environmental Friendly Sources of  
Energy*

*June 5th. 2008  
Blue Lagoon Hotel*

**Jon Bernodusson**  
**Icelandic Maritime Administration**  
*- Dep. of Research and Development -*

# *Transport and Climate Change*

## National Transport Policy 2007 – 2010

- Goal of Environmentally Sustainable Transport
  - Use of Environmental Friendly Main Engines in Fishing Vessels
- Transport Program for Research and Development
  - Environmental friendly Sources of Energy and Research on Reducing Energy in Fishing Vessels

# *Transport and Climate Change*

## Greenhouse Gases

- Carbon dioxide (CO<sub>2</sub>)
  - 1 kg of MDO gives 3.16 kg of CO<sub>2</sub> after combustion
- Other chemical substances
  - Nitrogen oxides (NO<sub>x</sub>)
  - Volatile organic compounds (VOC)

# *Transport and Climate Change*

## 3 methods to reduce the emission of CO<sub>2</sub>

- Reduction of fuel oil consumption
  - Catch methods, fishing gears and ship design
- Exhaust gas cleaning system
  - Facilities to separate and clean the exhaust gas
- Bio-Diesel (RME)
  - Carbon offsetting

# *Transport and Climate Change*

## MDO Consumption 1972 - 2007

Tons MDO		Tons CO <sub>2</sub>
● 1972 ≈ 120,000	->	(380,000)
● 1988 ≈ 220,000	->	(695,000)
● 1996 ≈ 285,000	->	(900,000)
● 2004 ≈ 265,000	->	(835,000)
● 2007 ≈ 255,000	->	(800,000)

MDO = Marine Diesel Oil

# *Transport and Climate Change*

## Reduction of Fuel Oil Consumption

- Fishing gears
  - Bottom and pelagic trawl (energy intensive)
  - Long lines and nets (energy efficient)
  - Seine (energy efficient)
- Ship types and design
  - Boats, purse seiners, small and large trawlers
- Main engines
  - Types, line and V-engines

# *Transport and Climate Change*

## Exhaust Gas Cleaning System

Facilities to separate and clean the exhaust gas

- Exhaust Gas Separator
  - Oil mist and oil fluid
  - NO<sub>x</sub> treatment
  - Water drops system
- Exhaust Gas Cleaner
  - Scrubbing with chemical solution
  - Collection of soot particles
  - End cleaning of exhaust gases

## EXHAUST GAS CLEANING SYSTEM

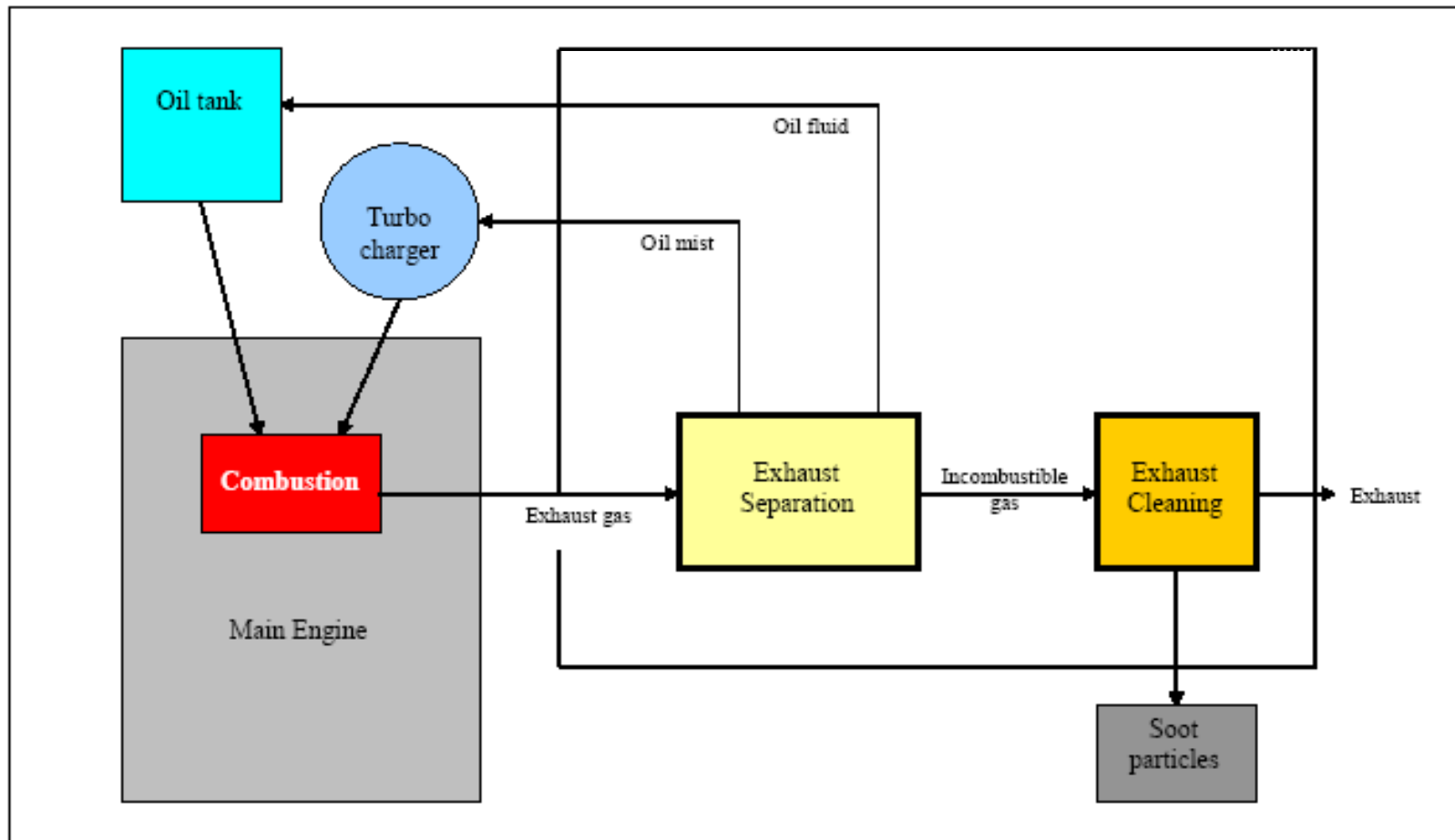

# EXHAUST CLEANER FOR MARINE ENGINES WITH CLOSED CIRCULATION SYSTEM

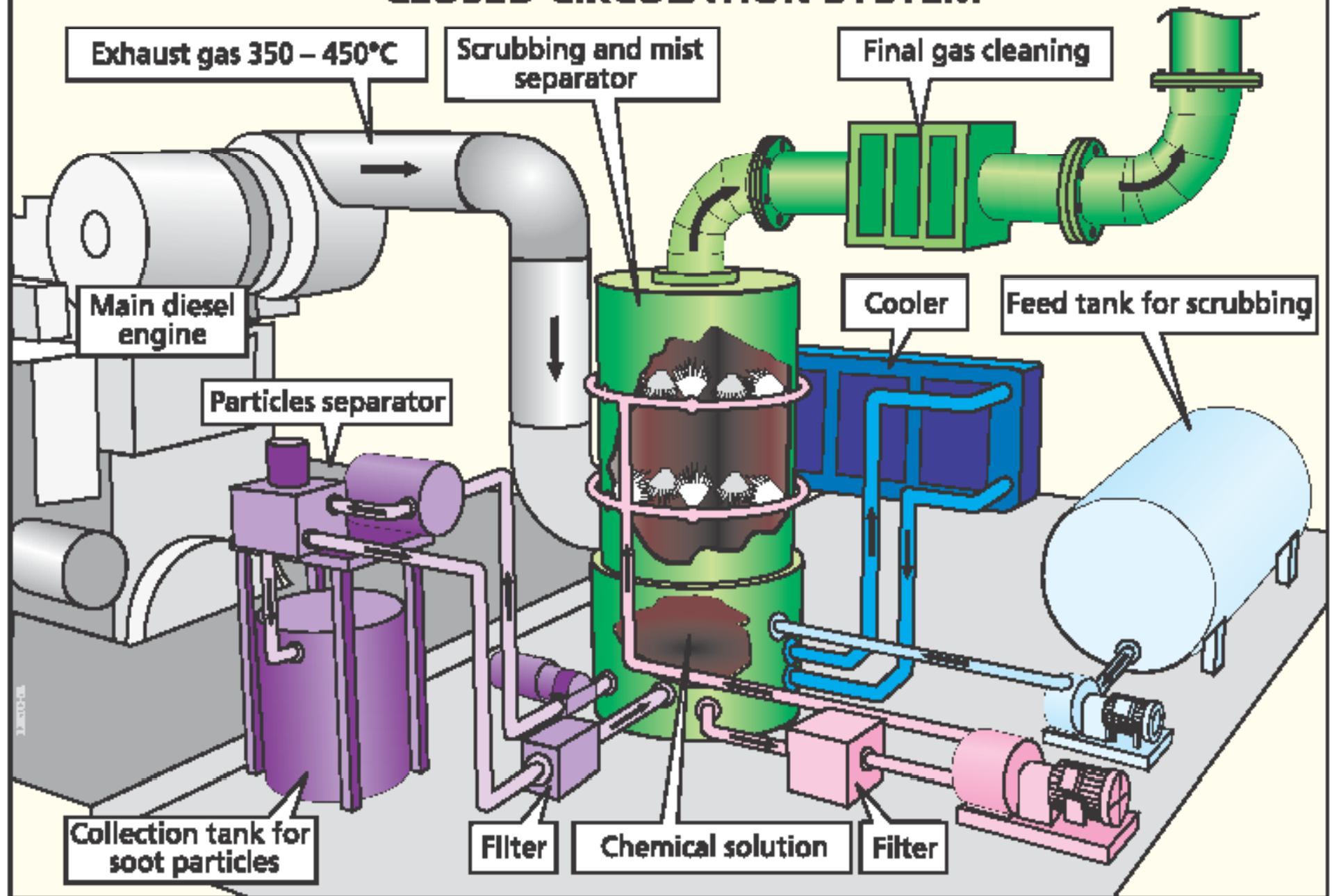

# *Transport and Climate Change*

## Bio Diesel (RME)

- Made of raps oil
  - Raps (Winter raps) can be cultivated in Iceland
  - One hectare gives 1,200 kg of raps oil
  - Byproduct is rich in protein for animal fodder
- Same quality as fossil fuel
  - Can be used for all diesel engines
  - Low sulphur, CO<sub>2</sub> and NO<sub>x</sub>
- Carbon offsetting
  - Carbon sequestration

# Biodiesel's Closed Carbon Cycle

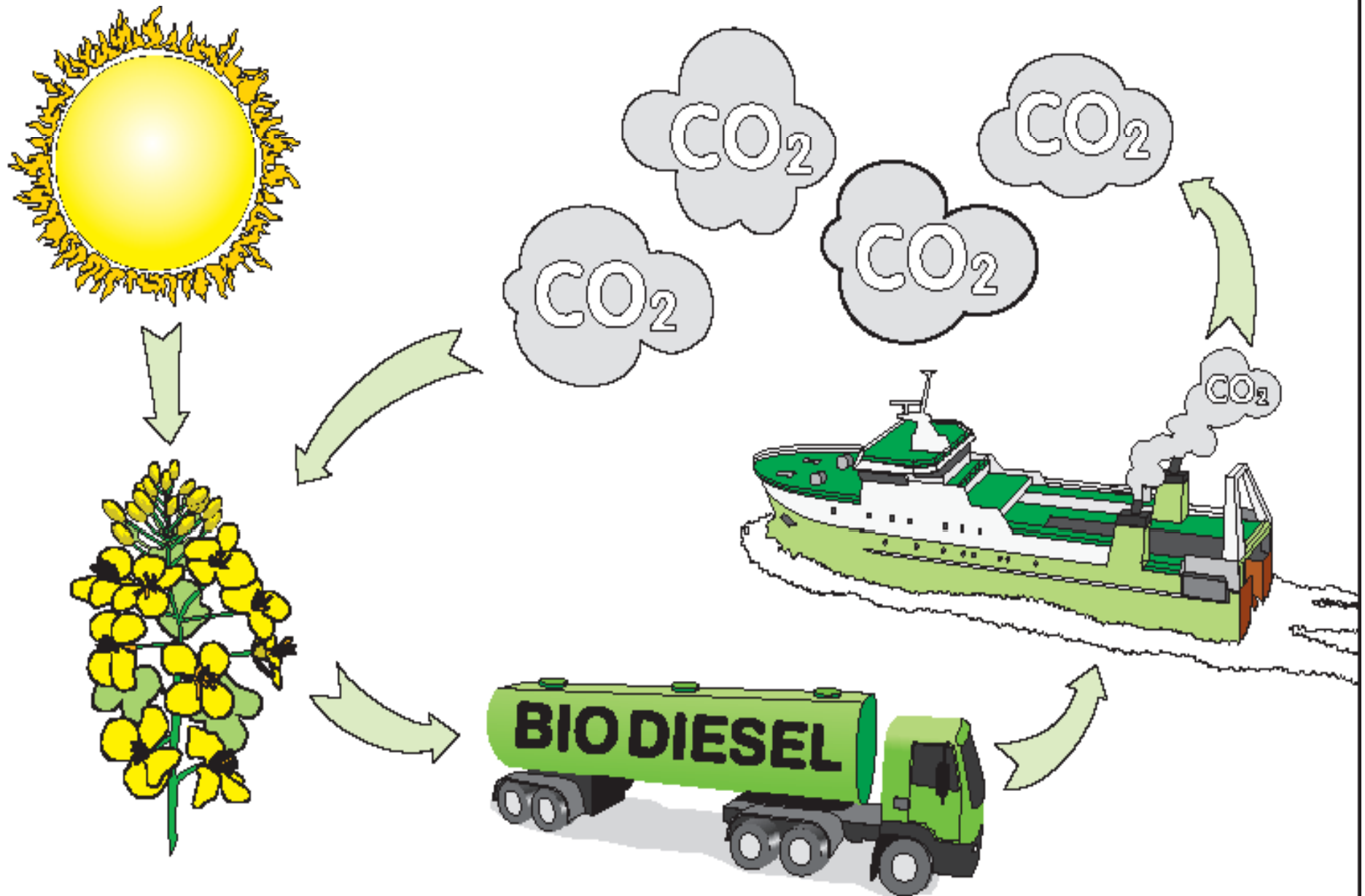

# Biodiesel Conversion Using Ultrasonication (continuous processing)

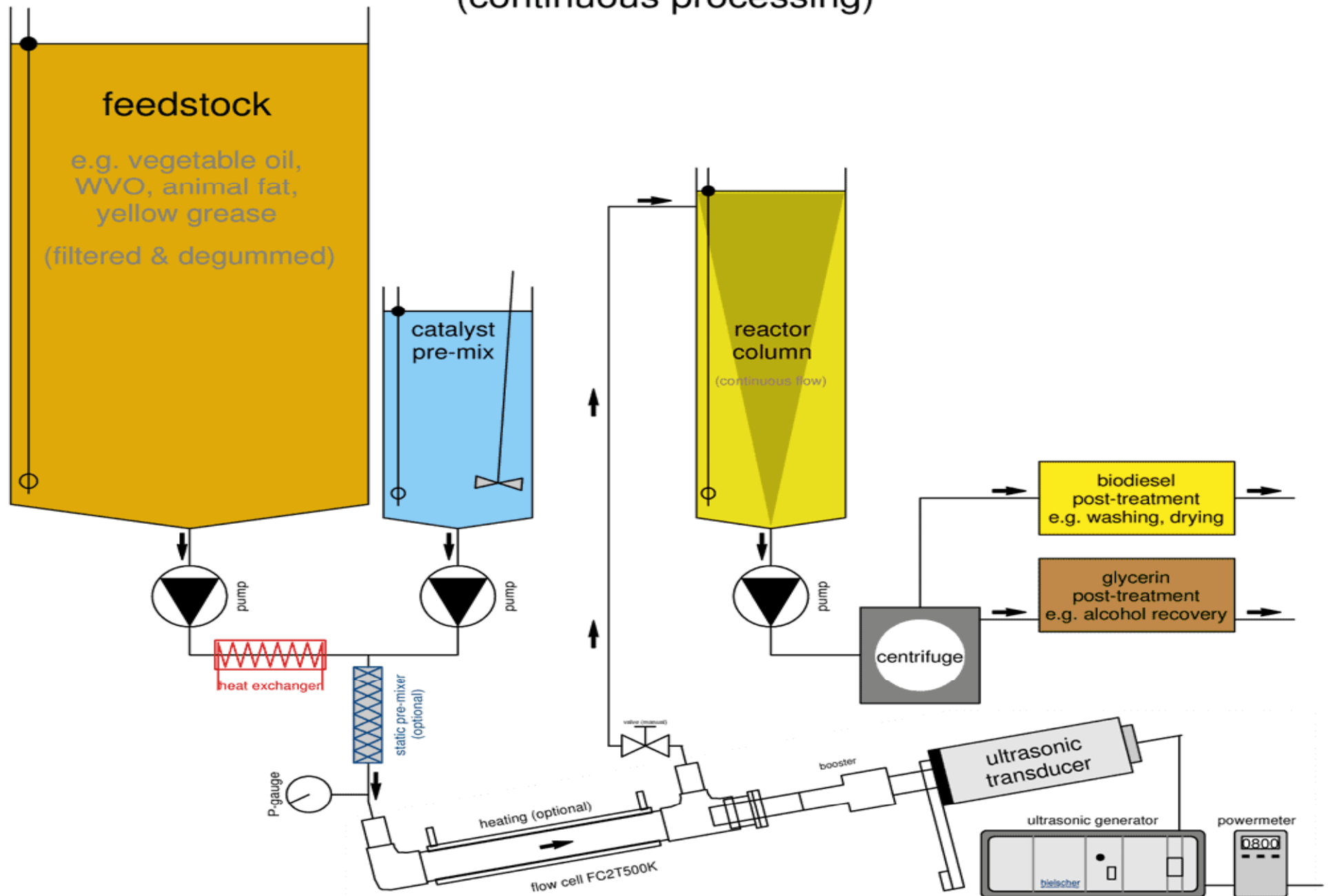

# *Transport and Climate Change*

## Atmosphere on board fishing vessels

- Research work at IMA
  - Fishing vessel as working space
  - Pollution
  - Measuring of CO<sub>2</sub>, H<sub>2</sub>S, CO
  - Measuring of oil mist and oil particles
- Lubricating oil mist separation
  - Main problem
- Publication 2009



# *Transport and Climate Change*

## Lub-oil separation

- Separation of lub-oil-mist from crank case (>90%)
- Separated lub-oil is returned again in to the crank case
- Cleaned air/gas returned to the turbo charger

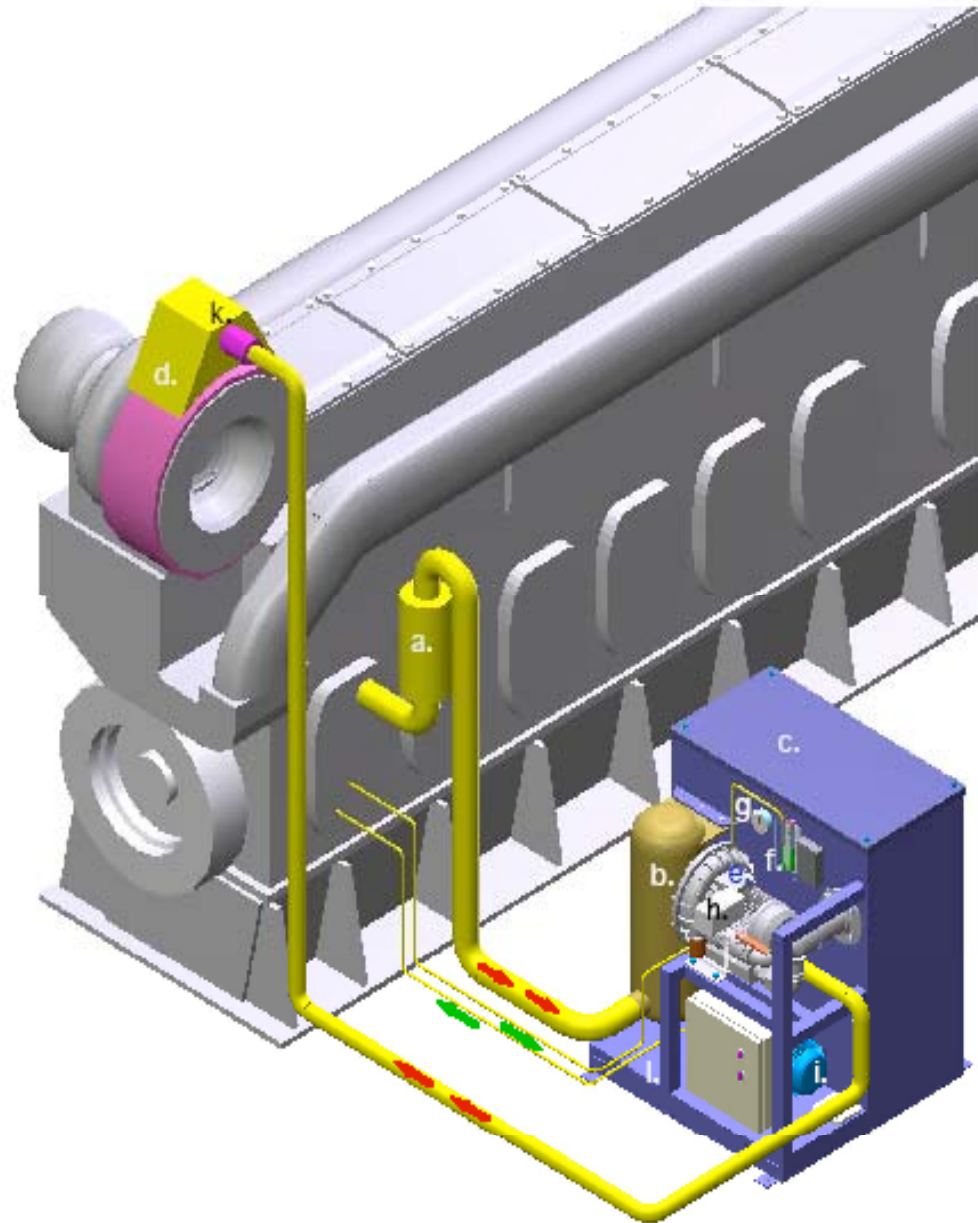

4T- VT- OGS2

# *Transport and Climate Change*

## Conclusions

- Changes in oil consumption
  - Oil consumption is decreasing due to lower allowed fish-catches
  - Oil prices are increasing and focus will be on more energy efficient fishing methods
- Exhaust cleaning system
  - Cleaning exhaust gas from existing engines
  - Cleaning lub-oil-mist out of the engine room.
- Bio-Diesel (RME)
  - Carbon offsetting
  - Made of raps which can grow in Iceland as winter raps
  - Sustainable development in oil production

# *Transport and Climate Change*



**Thank you**